

BIS RapidRail[®] Fixing system

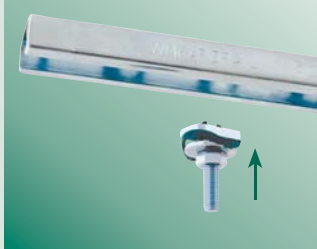

BIS RapidRail®

Fast and easy fixing



1. Insert



2. Turn 1/4 stroke



3. Slide



4. Lock

BIS RapidRail®

The BIS RapidRail® system offers an unprecedented choice for rail profiles and cantilever arms, plus an extensive range of accessories for pipe fixing and rail construction.

Insert, lock, done!

The accessories are pre-assembled and delivered 'ready-to-use' to the building site. The plastic spring allows the slide nut to be fixed into the rail easily. BIS RapidRail® is so easy to use, that it is possible to save up to 40% in fixing time!

Easy fixing to both sides of rail

BIS RapidRail® WM15 and WM30 have a unique hole pattern. The accessories can easily be used on both sides!

Also in stainless steel!

A selected range of BIS RapidRail® products such as rail profiles WM1, WM15 and WM2 and BIS RapidRail® Slide nut and Hammerfix are also available in stainless steel.

Your benefits:

- Quick and easy fixing to the rail
- Accessories pre-assembled 'ready-to-use'
- For all light and medium rail applications
- Rail WM15 and WM30 easy to use on both sides
- Saves up to 40% fixing time!



Fixing rails and cantilever arms

Complete range of fixing rail



BIS RapidRail® Fixing rail

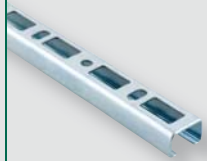

L (mm)	BIS RapidRail®					BIS Rapid38/40
	WM0 27 x 18 mm	WM1 30 x 15 mm	WM15 30 x 20 mm	WM2 30 x 30 mm	WM30 30 x 45 mm	WM14 38 x 40 mm
2000	650 5 000	650 5 001	650 5 015	650 5 002	650 5 030	650 5 014
6000	650 5 600	650 5 601	650 5 615	650 5 602	650 5 630	650 5 614

Surface treatment pre-galvanised

BIS RapidRail® Cantilever arms



L (mm)	BIS RapidRail®					BIS Rapid38/40
	WM0 27 x 18 mm	WM1 30 x 15 mm	WM15 30 x 20 mm	WM2 30 x 30 mm	WM30 30 x 45 mm	WM14 38 x 40 mm
150	660 3 015	660 3 115	660 3 715	660 3 215	-	660 3 615
200	660 3 019	660 3 120	660 3 720	660 3 220	-	660 3 620
250	-	660 3 125	660 3 725	660 3 225	-	660 3 625
300	-	660 3 130	-	660 3 230	-	660 3 630
400	-	-	-	660 3 240	660 2 340 ⁽¹⁾	660 3 640
450	-	-	-	660 3 245	-	660 3 645
500	-	-	-	660 3 250	660 2 350 ⁽¹⁾	660 3 650
600	-	-	-	-	-	660 3 660

Surface treatment zinc plated, ⁽¹⁾=Hot dip galvanised

BIS RapidRail® Wall plates



With the universal BIS RapidRail® Wall plate you can make your own cantilever arm on the job site. Just cut the rail to the right size, place it into the wall plate and the job is done! It is fast, easy and flexible.

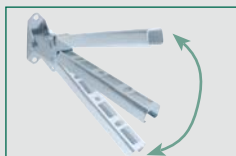

Type	BIS RapidRail®		BIS Rapid38/40
	WM0, 1, 15, 2 and 30	WM1, 15, 2 and 30	WM14
A	661 3 200	-	661 3 140 ⁽¹⁾
B	-	661 3 250 ⁽¹⁾	-

Surface treatment zinc plated, ⁽¹⁾=Not in BIS RapidRail® execution

BIS Rail end caps

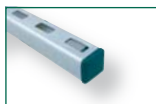
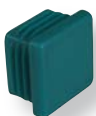

BIS RapidRail®					BIS Rapid38/40
WM0	WM1	WM15	WM2	WM30	WM14
656 6 000	656 6 001	656 6 000	656 6 002	656 6 030	656 6 041

BIS RapidRail® Accessories

For pipe fixing

BIS RapidRail® Slide nuts

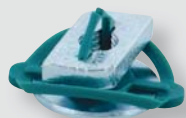

Type	BIS RapidRail®	BIS Rapid38/40
	WM0, 1, 15, 2 and 30	WM14
M6	651 3 106	651 4 106
M8	651 3 108	651 4 108
M10	651 3 110	651 4 110

BIS RapidRail® Hammerfix

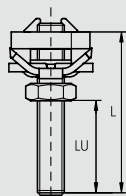

L (mm)	LU (mm)		BIS RapidRail®			BIS Rapid38/40	
	M6/M8	M10	WM0, 1, 15, 2 and 30			WM14	
			M6	M8	M10	M8	M10
20	5	-	652 3 602	-	-	652 4 802	-
25	10	7	-	652 3 802	652 3 002	-	-
30	15	12	652 3 603	652 3 803	652 3 003	652 4 803	652 4 003
40	25	22	652 3 604	652 3 804	652 3 004	652 4 804	652 4 004
50	35	32	-	652 3 805	652 3 005	652 4 805	652 4 005
60	45	42	-	652 3 806	652 3 006	652 4 806	652 4 006
70	55	52	-	652 3 807	652 3 007	652 4 807	-
80	65	62	-	652 3 808	652 3 008	652 4 808	652 4 008
90	75	72	-	652 3 809	652 3 009	-	652 4 009
100	85	82	652 3 610	652 3 810	652 3 010	652 4 810	652 4 010
120	105	-	-	652 3 812	-	-	-
150	135	-	-	652 3 815	-	652 4 815	-
160	145	142	-	652 3 816	652 3 016	-	-
180	165	162	-	652 3 818	652 3 018	-	-
200	185	-	-	652 3 820	-	-	-

BIS RapidRail® Hammerfix female thread

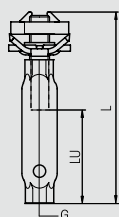

G	L (mm)	LU (mm)	BIS RapidRail®
			WM0, 1, 15, 2 and 30
M8	60	35	652 0 020
M10	60	35	652 0 030

BIS RapidRail® Ball swivel hangers

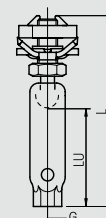

G	L (mm)	LU (mm)	BIS RapidRail®
			WM0, 1, 15, 2 and 30
M8	50	7	652 0 100
M10	50	7	652 0 110
M8	75	32	652 0 200
M10	75	32	652 0 210

BIS RapidRail® Accessories

For rail construction

BIS RapidRail® T-connector

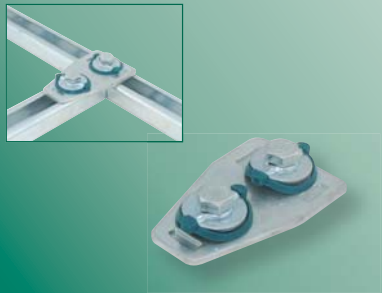

Part No.	Type
658 4 090	T

BIS RapidRail® X-connector



Part No.	Type
658 4 091	X

BIS RapidRail® Connector

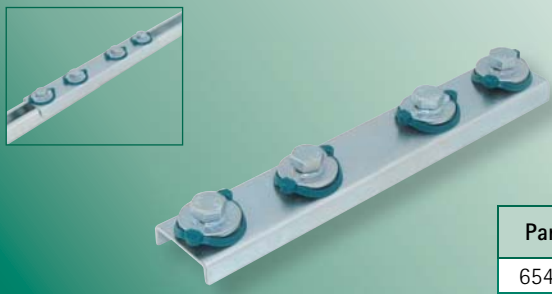

Part No.
654 3 001

BIS RapidRail® Cross connectors

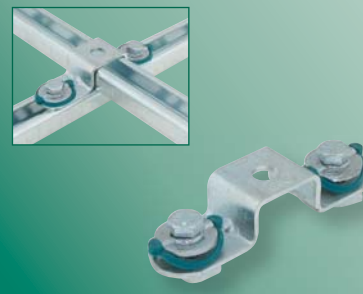

Part No.	For
658 4 150	WM0
658 4 151	WM1
658 4 152	WM15
658 4 153	WM2

BIS RapidRail® Connectors 90°



	Part No.
1	658 4 003
2	658 4 002
3	658 4 001
4	658 4 011

BIS RapidRail® Connectors 135°



	Part No.
1	658 4 053
2	658 4 052
3	658 4 051
4	658 4 061

BIS RapidRail® Beam clamps



Part No.	For
658 5 011	WM0, 1, 15, 2 and 30
658 5 014	WM14

BIS RapidRail® Suspension bracket



Part No.
679 3 008

Accessories for BIS RapidRail®

For rail construction

BIS Rail angle brackets



Part No.	For
660 3 010	WM0, 1, 15, 2 and 30
660 3 020	WM14

BIS Rail junction angle brackets



Part No.	For
659 3 010	WM0, 1, 15, 2 and 30
659 3 020	WM14

BIS Rail junction assembly



Part No.	For
661 3 820	WM1, 15, 2 and 30

BIS Rail props

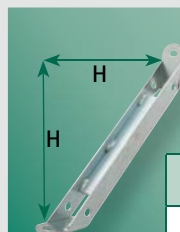

Part No.	H (mm)	For
662 8 220	250	WM0, 1, 15, 2 and 30
662 8 230	350	WM0, 1, 15, 2 and 30
662 8 530	295	WM14

BIS Angle formed slide nut



Part No.	G	For
651 3 709	M8	WM1, 15, 2 and 30

BIS Square nuts



Part No.	G	For
651 9 910	M6	WM1, 15, 2 and 30
651 9 911	M8	WM1, 15, 2 and 30
651 9 912	M10	WM1, 15, 2 and 30
651 9 913	M12	WM1, 15, 2 and 30

BIS Double slide nut

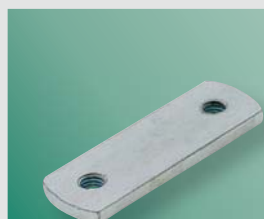

Part No.	G	For
651 3 208	M8	WM0, 1, 15, 2 and 30

BIS Rubber strip



Part No.	L	For
656 8 001	30 m	WM0, 1, 15, 2 and 30

BIS RapidRail® Stainless Steel

Made to last

The zinc plated BIS RapidRail® fixing rails and accessories are perfectly suitable for most situations. However, in the food industry, laboratories, sewage treatment plants, tunnel building or other corrosive

surroundings generally stainless steel must be applied. For this purpose the commonly used BIS RapidRail® range is also available in stainless steel 1.4401 (AISI-no 316).



BIS RapidRail® Fixing rail



L (mm)	WM1 30 x 15 mm	WM15 30 x 20 mm	WM2 30 x 30 mm
2000	650 7 001	650 7 015	650 7 002

BIS RapidRail® Cantilever arms

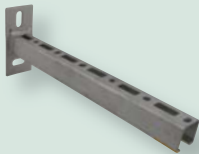

L (mm)	WM1 30 x 15 mm	WM2 30 x 30 mm
200	660 7 120	-
300	-	660 7 230
500	-	660 7 250

BIS RapidRail® Wall plate



WM1, 15 and 2
661 7 200

BIS RapidRail® Slide nuts

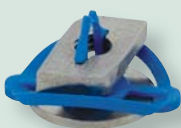

Type	WM1, 15 and 2
M6	651 7 306
M8	651 7 308
M10	651 7 310

BIS RapidRail® Hammerfix

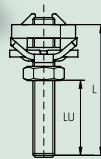

L (mm)	LU (mm)		WM1, 15 and 2		
	M6/M8	M10	M6	M8	M10
25	11	-	652 7 062	-	-
40	25	22	-	652 7 084	652 7 094
80	65	62	-	652 7 088	652 7 098

BIS RapidRail® Beam clamps



Part No.	For
658 7 011	WM1, 15 and 2

BIS Rail prop

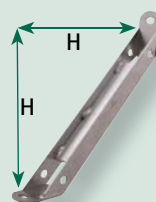

Part No.	H (mm)	For
662 7 220	250	WM1, 15 and 2

The right combination

The Walraven range includes many other products which can be perfectly used in combination with the BIS RapidRail® fixing system.

Possible combinations:

- starQuick®
- BISMAT® Flash
- BIS TSM Concrete screws

starQuick®

starQuick® Pipe clamps guarantee a reliable and time-saving pipe fixing. The starQuick® clamp is self-locking: the clamp closes when the pipe is pushed into it!

With the starQuick® Hammerfix a starQuick® clamp is fixed onto a BIS RapidRail® Fixing rail quick and simple.

- Self-locking system
- For all pipe types from Ø 10 to 65 mm
- An extensive range of accessories
- Corrosion-free pipe fixing



starQuick® Hammerfix

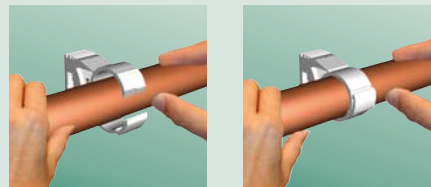

Place pipe into clamp

Push to fix and lock!



BISMAT® Flash

Save even more on labour? Try BISMAT® Flash! This clamp has a state-of-the-art quick locking system. The locking screw can be secured by one simple thumb push. Tools are not required!

The BISMAT® Flash is suitable for fixing of metal pipe Ø 15 to 51 mm (3/8 to 1 1/2"). The BISMAT® Flash is available with connection nut M8 or M8/M10.

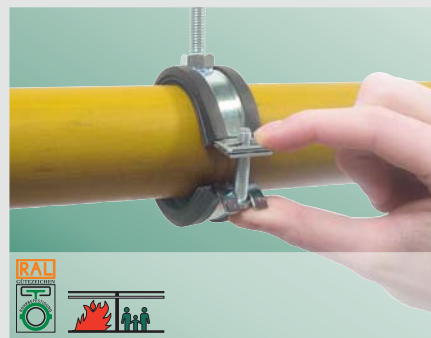

BIS TSM Concrete screws

BIS TSM Concrete screws are suitable for fixing of pipes, cladding units, fixing rails onto concrete. Without plug. Save time and material! The domed headed version can be perfectly used in combination with BIS RapidRail® Fixing rail.

The screws withstand dynamic loads and fire for 120 minutes. Suitable for both cracked and non-cracked concrete, sand-lime brick, clinker, brick, natural stone, etc.



The Netherlands Scandinavia - Finland

Walraven B.V.
P.O. Box 15
3640 AA Mijdrecht (NL)
Tel. +31 (0)297 23 30 00
Fax +31 (0)297 23 30 99
info@walraven.com



United Kingdom Ireland

Walraven Ltd.
Thorpe Way, Banbury (GB)
Oxon, OX16 4UU
Tel. +44 (0)1295 75 34 00
Fax +44 (0)1295 75 34 28
sales.banbury@walraven.com



Germany

Austria - Switzerland - South East Europe

BIS Walraven GmbH
Postfach 125128
95425 Bayreuth (DE)
Tel. +49 (0)921 75 60 0
Fax +49 (0)921 75 60 111
info@bis-walraven.de

Other countries

Walraven International
P.O. Box 15
3640 AA Mijdrecht (NL)
Tel. +31 (0)297 23 30 00
Fax +31 (0)297 28 64 09
export@walraven.com



Walraven Group

Mijdrecht (NL) · Tienen (BE) · Bayreuth (DE)
Grenoble (FR) · Banbury (GB) · Madrid (ES)
Mladá Boleslav (CZ) · Kraków (PL) · Kyiv (UA)
Detroit-Wixom (US)

www.walraven.com

Your wholesaler: