

wavin

OSMA

Delivering Advantages on Site



Meeting your needs

OSMA drainage systems, developed by Wavin Plastics Limited, provide intelligent solutions and unique advantages on site for all building, construction and utilities programmes.

The range includes solutions for:

Above Ground Projects

- OSMA Rainwater systems
- OSMA Soil & Waste systems

Plumbing & Heating Projects

- OSMA Flexible Plumbing systems
- OSMA Underfloor Heating systems

Below Ground Projects

- OSMA Below Ground Drainage systems
- OSMA Water Management systems
- OSMA Ducting systems

Pressure Pipe Projects

- OSMA Pressure Pipes for Water



ISO 9001:2000

All OSMA systems are backed by full technical literature and project support. See inside back cover for details.

Wavin Plastics Limited operates a programme of continuous product development, and therefore reserves the right to modify or amend the specification of their products without notice. All information in this publication is given in good faith, and believed to be correct at the time of going to press. However, no responsibility can be accepted for any errors, omissions or incorrect assumptions. Users should satisfy themselves that products are suitable for the purpose and application intended.

wavin

Wavin Plastics Limited

Parsonage Way

Chippenham

Wiltshire SN15 5PN

Tel: 01249 766600

Fax: 01249 443286

Email: info@wavin.co.uk

www.wavin.co.uk

CORP104



Uniclass | EPIC
JR1 L2123+L731 P71 | B213 J34+J35
CI/SIB | (52) | n6
February 2005 | CORP104
Rev. Feb 2006



delivering advantages
on site

Intelligent Solutions for Construction Projects

OSMA from Wavin



OSMA, from Wavin Plastics Limited, is one of the leading and most widely recognised names in the building industry. OSMA systems, precision-manufactured in the UK, are the benchmark for innovation and excellence. All products comply with or exceed relevant British and European standards to ensure reliability and long-lasting service.

Intelligent connections

OSMA systems offer integrated solutions. This enables specifiers and installers to assemble complete drainage, plumbing and heating, and pressure pipe systems from a single source, with complete confidence in compatibility and performance.

All systems are backed by comprehensive technical support and a nationwide distribution network to ensure availability when and where required.

Wavin is one of the largest producers of plastic pipe and fittings in the world, and credited with inventing and pioneering the use of plastic pipe for water distribution in the mid 1950s.

The company is committed to environmental responsibility, and was the first plastic pipe manufacturer to be accredited to BS EN ISO 14001 Environmental Management Systems.

Leader in Europe

Wavin is the leading converter of plastics in Europe, and operates in 27 countries across the continent. This ensures we have the resources to supply even the largest projects, and enables us to offer our customers best value procurement in all product areas.

We maintain an industry-wide dialogue and rigorous assessment of all procedures to ensure that Wavin product development and product support accurately addresses the needs of all our customers – today and into the future.

Total project support

Wavin is committed to taking costs out of the supply chain, and to providing our customers with total project support.

- Dedicated Key Account Management – so that customers have a single point of contact for all account matters
- A partnership approach to working with customers – to achieve mutually agreed objectives
- Full technical advice and assistance, including:
 - Fully detailed technical literature
 - CAD product and application details on disk
 - Computer aided project design, showing optimum system configuration and a detailed schedule of all components
 - Full specification service
 - On site advice and troubleshooting
 - Design and production of bespoke fittings to meet specific application requirements
 - The complete OSMA product catalogue, together with design and installation guidance, available online at www.wavin.co.uk

Delivering Advantages on Site



– All literature can be downloaded via searchable PDF library at www.wavinpdfs.co.uk

– Wavin images can be downloaded at different resolutions from www.wavinimages.co.uk

Wavin is committed to continuous technical and product development. This has kept OSMA at the forefront of the UK building industry. And ensures that OSMA systems continue to offer the most reliable, versatile and cost-effective solutions to the challenges facing the building and construction industry today. The OSMA products and systems featured in this brochure offer design innovations to:

- Simplify installation
- Provide cost-effective solutions to individual project requirements
- Meet changing legislative requirements
- Deliver cost and time advantages on site

Ask Now

For further information

For product literature

CALL: 01249 766333

Technical enquiries

CALL: 01249 766655

Arrange a meeting

CALL: 01249 766369

Email

For all services: info@wavin.co.uk

See also: www.wavin.co.uk

Building Drainage 4-5

Lightweight, robust PVC-U systems for all below ground drainage requirements

Inspection Chambers 6-9

For safe, efficient and cost-effective access

Manholes, Gullies, French Drains, SUDS and Highway Drainage 10-11

Reducing installation time and costs

Sewers for Adoption 12-13

Structured wall system for all foul and surface water systems

Channel Drainage 14-17

Highly efficient and durable systems for drainage of paved areas

Stormwater Management 18-21

Versatile and cost effective solutions for sustainable development (PPG25 & Part H3)

Rainwater and Soil & Waste Drainage 22-23

Integrated solutions for all above ground needs

OsmaDrain Building Drainage

Pipe Bore

up to 82mm (nominal)

Over 100-150mm (nominal)

Over 150-300mm (nominal)

Unrivalled in scope and quality, this renowned PVC-U gravity drainage system offers a comprehensive range of bends, junctions, adaptors and access fittings to meet the requirements of all drainage layouts.

- Available in 82mm, 110mm and 160mm diameters
- May be installed at depths up to 10 metres
- Meets all relevant BS and EN standards, including BS 4660: 1989 and BS EN 1401-1: 1998
- 110 and 160mm systems carry BBA Certificate 87/1835

Versatile and easy to use

The OsmaDrain system is fully integrated to ensure maximum flexibility in use, offering unique benefits on site:

- Lightweight, for easy handling – meeting health and safety requirements
- Robust construction, resists damage during installation
- Simple and secure jointing, saving time and costs
- Good self cleansing properties
- Reduces the risk of blockages occurring
- Full range of adaptors and connectors to other systems and materials

Applications

The 110mm and 160mm systems are suitable for both foul and surface water drainage in non-adoptable situations.

The 82mm system is ideal for surface water drainage from small buildings and for applications such as the venting of petrol interceptors.

Bedding

Excavated 'as dug' material may be used for bedding and sidefill so long as the maximum particle size is in accordance with **Table 1** above (as per requirements defined in BS 5955: Part 6: 1980).

Where as-dug material is unsuitable, use imported processed material in accordance with the specifications in **Table 1**.

When bedding pipes

- 1 Lay the pipes true to line and level within the specified tolerances
- 2 Check each pipe and make any necessary adjustments to level by raising or lowering the formation
- 3 After laying pipe, carefully fill depressions to ensure no voids remain under, or around, sockets

Backfill

Backfill by placing suitable sidefill material simultaneously on each side of the pipe in 100mm layers.

If 'as-dug' material is free from stones exceeding 40mm:

Cover the pipe crown with a minimum of 300mm of compacted 'as-dug' material

If 'as-dug' material contains stones larger than 40mm, or the pipe is deeper than 2m in poor ground:

Use processed granular material for at least 100mm above the pipe crown.

Fig. 1 OsmaDrain pipes laid on trench bottom

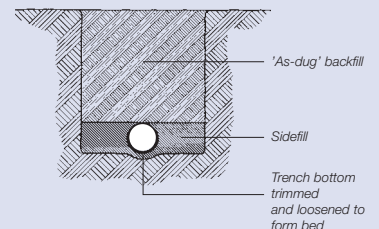

Fig. 2
mum

OsmaDrain and Osma UltraRib pipes laid on a 50mm minimum processed granular bed.

Where the trench bottom can be hand trimmed by shovel and is not puddled when walked upon, a 50mm depth of bedding material may be used. In this case the material must be nominal 10mm single-sized aggregate (see Figure 2).

OsmaDrain and Osma UltraRib pipes laid on a 100mm minimum processed granular bed.

Where the trench bottom cannot be hand trimmed by shovel and is puddled when walked upon, or, when pipes are to be laid in rock, compacted sand or gravel requiring mechanical means of trimming, or, in very soft or wet ground, the bedding should be a minimum of 100mm of processed granular material in accordance with **Table 1** (see also Figure 3).

Key Installation Details

Table 1: Suitable Bedding and Sidefill Materials

Particle Size	Material Specification (see Note)
10mm (nominal max)	10mm nominal single size
15mm (nominal max)	10 or 14mm nominal single size or 14mm to 5mm graded
20mm (nominal max)	10, 14 or 20mm nominal single size or 14mm to 5mm graded or 20mm to 5mm graded

Note: Aggregates conforming to BS 882, air cooled blast furnace slag conforming to BS 1047, or lightweight aggregate conforming to BS 3797 are suitable as processed bedding and sidefill materials

Osma UltraRib pipes laid on 50mm mini-processed granular material

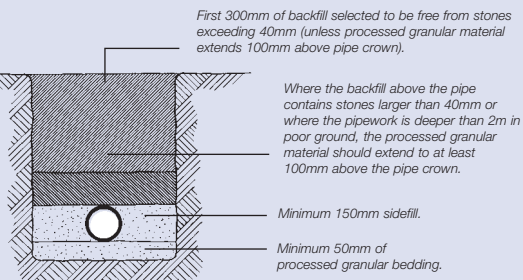

Fig. 3 UltraRib pipes laid on 100mm minimum of processed granular material

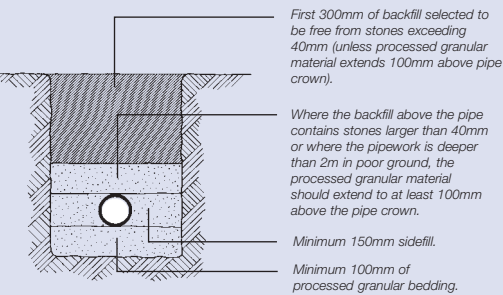
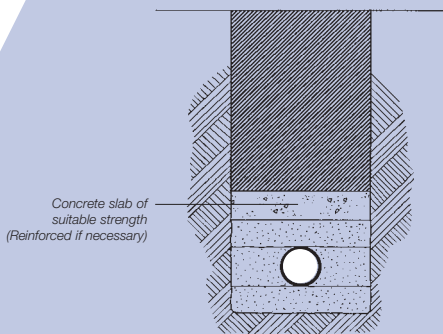

Fig. 4 Pipe protection – concrete slab



Protection

Traffic free areas

Protect pipes at depths less than 0.6m by placing a layer of concrete paving slabs over the pipe run, with at least a 75mm layer of suitable material between pipe and slab.

Public highways/adoptable situations

Where loading is expected, protect pipes at depths less than 0.9m below the finished surface of a road (1.2m in adoptable situations) EITHER:

- With a concrete* slab of suitable strength extending the full width of the trench.
- OR by surrounding the pipes in concrete*.

*Strength of concrete required, or requirement for reinforced concrete, to be determined by the engineer or adopting authority.

Fig. 5 Pipe protection – concrete surround

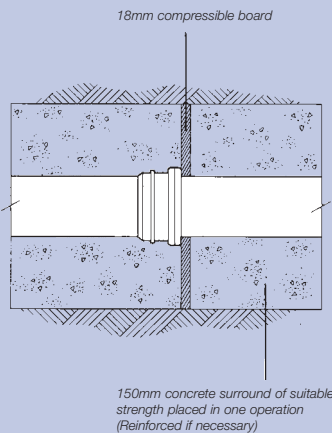

Building Drainage

Vertical connections

A complete range of components enables connection to any standard rainwater, soil or waste pipe.

Fig. 6 Connection of internal waste pipe at depth

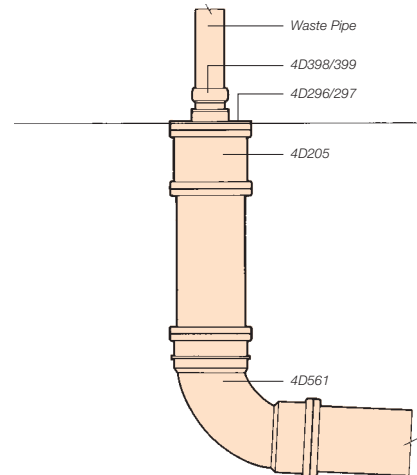

For further details, and for information regarding any situation not covered here, please see the OSMA Below Ground Design and Installation Guide or call:

Technical Design
01249 766655

Inspection Chambers

OSMA Inspection Chambers provide a safe and effective method of providing access to the drainage system, with options to meet all access and layout requirements. The range includes:

	Max. Depth to Invert (m)
Shallow Inspection Chamber (SIC)	0.6
Multi-Base Inspection Chambers (SIC)	0.6
Universal Inspection Chambers (UIC)	1.2
Non-Entry Inspection Chamber (NIC)	3.0

Simple and easy to install

OSMA Inspection Chambers offer significant advantages over traditional manholes in both time and cost:

- No need for wet trades
- No additional excavation required
- Quick and easy connection to pipe runs
- Satisfies all regulatory requirements for access provision
- Range of configurations to meet all drainage layout requirements
- Round and square cover options, for trafficked and non-trafficked areas

Access requirements

Requirements are set out in Part H1 of Approved Document H, (Edition 2002). Guidance is also provided in BS EN 752-3: 1997. Access should be provided:

- On or near the head of each drain run
- At a bend and at a change in gradient
- At a change of pipe size (*but see opposite if at a junction*)
- At a junction, unless each run can be cleared from an access point (some junctions can only be rodded through from one direction).

Fig. 7 Maximum manhole/inspection chamber spacings

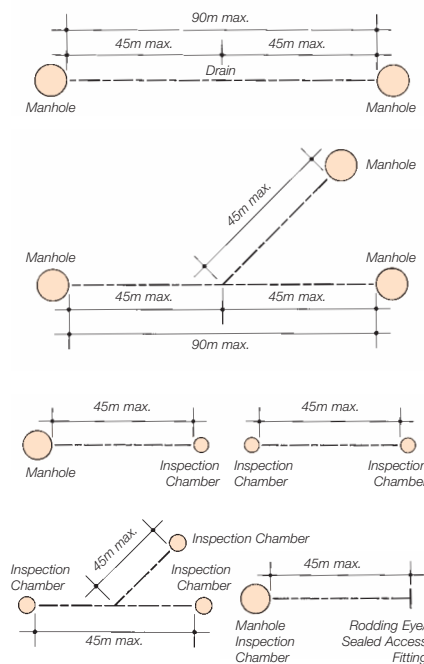

Universal Inspection Chambers

For use with 110mm and 160mm OsmaDrain pipework and 150mm UltraRib.

- Suitable for 1200mm depths
- 450mm diameter system
- Use Shaft Sections as required to achieve invert – reduces waste
- Fully socketed connections for ring seal jointing

Chamber bases for OsmaDrain

- 110mm D/S Equal Inspection Chamber Base 4D922
- 160mm D/S Equal Inspection Chamber Base 6D928
- 160mm D/S Unequal Inspection Chamber Base 6D929

Chamber bases for UltraRib

- 150mm D/S Equal Inspection Chamber Base 6UR928
- 150mm D/S Unequal Inspection Chamber Base 6UR929

Fig. 8 110mm D/S Equal Inspection Chamber Base

Nominal Size	Part Number	Invert Depth	A	B	C
110	4D922	270	475	297	594

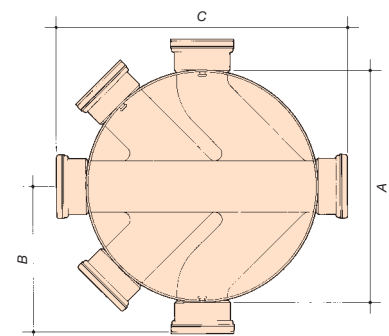

Cover options

- Polypropylene Square Cover and Frame 4D943
- Polypropylene Round Cover and Frame 4D947
- Ductile Iron Cover and Frame 4D942 Lloyds Reg Qual 
- Square Recessed Steel Cover and Polypropylene Frame 4D945
- Square Recessed Sealed Steel Cover and Polypropylene Frame 4D946

UIC Key installation points

- Sit the Chamber Base on a minimum 100mm of bed of 'as-dug' or granular material
- Achieve necessary invert depth by installing Shaft Sections as required:
 - Base plus one Shaft Section = 500mm (540mm with cover)
 - Base plus two Shaft Sections = 730mm (770mm with cover)
 - Base plus three Shaft Sections = 960mm (1000mm with cover)
 - Base plus four Shaft Sections = 1190mm (1230mm with cover)
- For loading situations up to 125kN (12.5 Tonnes), provide a 150mm concrete plinth on which to sit the cover and frame

Note: For intermediate depths cut the Shaft Section as necessary. Use the concentric grooves at 10mm centres around the Shaft Section as cutting guides

Fig. 9 160mm D/S Equal Inspection Chamber Base

Nominal Size	Part Number	Invert Depth	A	B	C
160	6D928	270	480	370	740

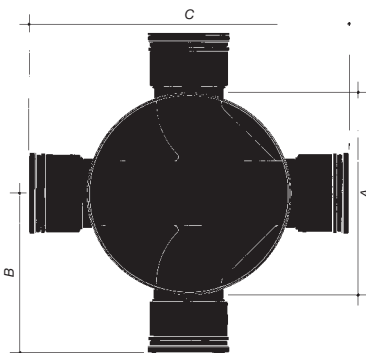

Fig. 11 Universal Inspection Chamber – non-load installation

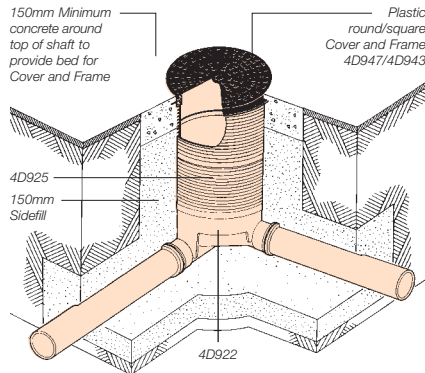

Fig. 12 Universal Inspection Chamber – in areas requiring a BS EN 124-B125 Cover and Frame

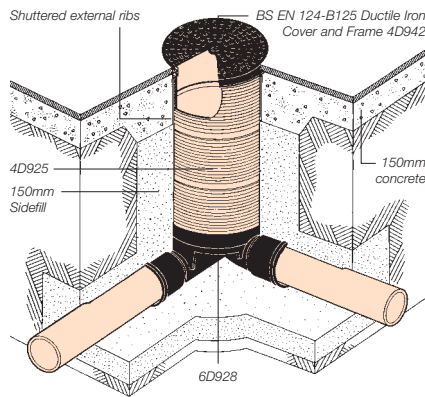
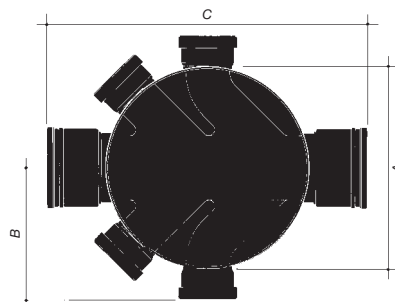

Fig. 10 160mm D/S Unequal Inspection Chamber Base

Nominal Size	Part Number	Invert Depth	A	B	C
160x110	6D929	270	480	315	740



Shallow Inspection Chamber

- D/S Shallow Inspection Chamber 4D960 for use with the 110mm OsmaDrain system
- Ideal cost-effective solution for access to drains at max. 600mm invert
- Manufactured as a single unit with a straight 110mm main channel and two 45° 110mm inlets, one either side of the main channel
- Unit supplied with two blank-off plugs to seal unused side entries

Inspection Chambers

Cover options

- S/S Sealed Round Cover and Frame 4D325
- P/E Sealed Square Cover and Adjustable Frame 4D961

Key installation points

- For loadings up to 10kN (1 Tonne) support frame with 150mm concrete plinth

Fig. 13 Shallow Inspection Chamber installation

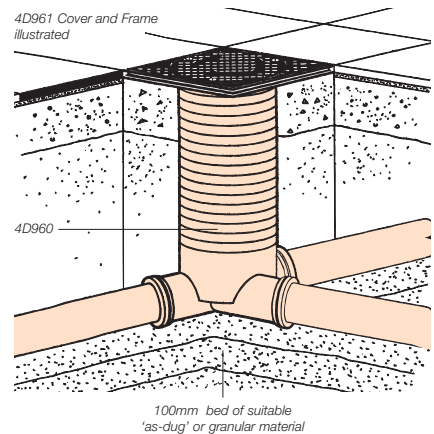

Inspection Chambers continued

Multi-Base Shallow Inspection Chambers

A range of ten unique 110mm base configurations with push-fit shaft, tilt and rotate push-fit cover and frame.

- 300mm diameter bases
- For use to maximum invert depth of 600mm
- Direct connection to 110mm OsmaDrain pipe

Maximum flexibility

The many options within the range ensures maximum flexibility for installation

- By selecting the most appropriate base for the job, the cost of additional bends is avoided
- One or two push-fit shaft sections may be used to achieve invert required

All bases carry a kitemark and are fast and easy to install, and avoid the need for additional trench excavation.

Cover

P/E Cover and Adjustable Frame 4D969. Not suitable for internal use.

Fig. 14 Multi-Base Shallow Inspection Chamber installation

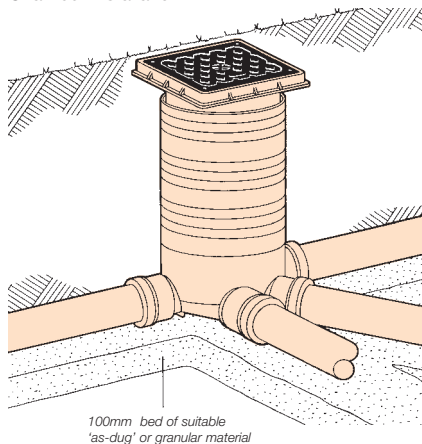

Key installation points

- Lubricate the inside of either one or two Shaft Section(s) 4D937, depending on the depth of invert required, and push-fit onto the base unit. Achieve intermediate depths by cutting the Shaft Section to the required depth – use the concentric grooves at 30mm centres along the shaft section as cutting guides
- For loadings up to 10kN (1 Tonne), support frame with 150mm concrete plinth
- Lubricate inside of the shaft section. Push-fit the Cover and Adjustable Frame 4D969 directly into the top of the shaft section

Fig. 15 Multi-Base Shallow Inspection Chamber components

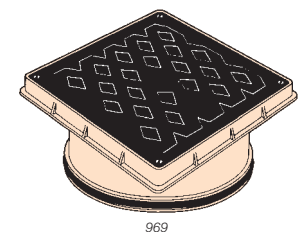
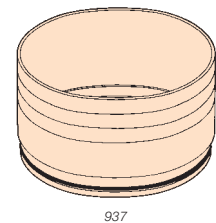
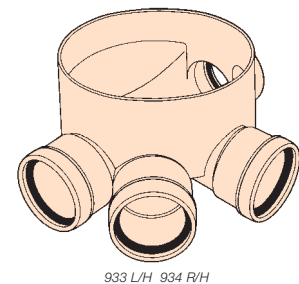
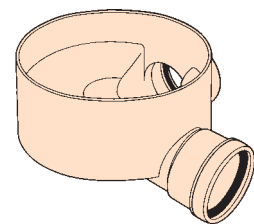
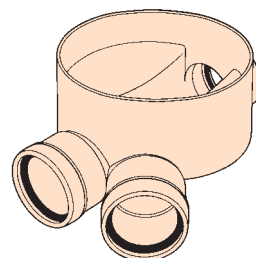
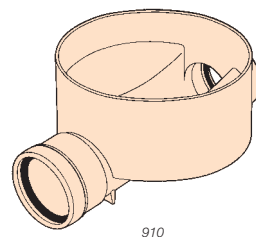

Non-Entry Inspection Chamber (NIC)

For use with:

- 110mm and 160mm OsmaDrain underground drainage systems
- 150mm OSMA UltraRib foul and surface water sewer systems
- 150mm OSMA TwinWall surface and stormwater drainage systems via adaptors

The OSMA Non-Entry Inspection Chamber (NIC) provides non-man entry access to depths up to 3 metres, meeting revised Part H 2002. It is suitable for domestic and non-adoptable industrial/commercial applications.

- 110mm D/S Equal Inspection Chamber Base 4D923 available
- Shafts available in 1.5m and 3m lengths
- Kitemarked to BS 7158:2001, Plastic Inspection Chambers for Drains & Sewers
- Tested and acknowledged as a system fit for purpose in accordance with the revised Part M of the Scottish Building Regulations
- No requirement to work in a confined space (in line with Confined Spaces Legislation 1997)
- Deemed 'fit for purpose' by: NHBC (National House Building Council), LANTAC (Local Authority National Type Approval Consortium) and STAS (Scottish Type Approval Scheme)

Fig. 16 D/S Equal Inspection Chamber Base

Nominal Size	Part Number	Invert Depth	A	B	C
160	6D936	300	740	315	587

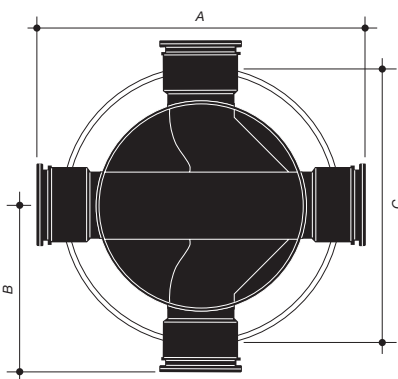

This lightweight unit has traffic resistant capability, thus avoiding the need to use the traditional concrete ring alternative.

- Easy and fast installation within paved surfaces
- 450mm opening size for use to depths up to 1.2m
- 350mm opening size for use to depths up to 3m
- When the frame is supported by a concrete plinth, may be used in areas requiring a loading of up to 50kN (5 tonnes), e.g. domestic driveway



Fig. 17 D/S Unequal Inspection Chamber Base

Nominal Size	Part Number	Invert Depth	A	B	C
160	6D937	300	740	315	587

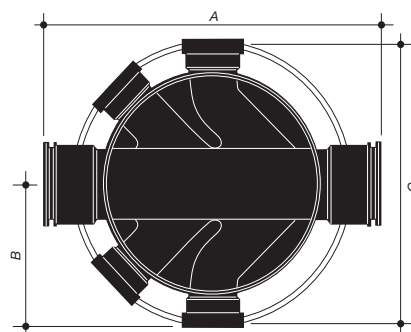

Inspection Chambers continued

Key installation points

- Once backfilled to ground level, cut shaft as necessary – using a fine toothed saw – to achieve required depth for installation
- Select and install appropriate cover and frame according to depth of installation:
 - Depth to invert <1.2m: use 4D943
 - Depth to invert >1.2m: use 6D931
- Surround cover and frame according to loading requirement:
 - Foot traffic only: frame may be simply bedded on backfill
 - Loading up to 50kN (5 Tonnes) e.g. domestic driveways: cast concrete plinth 150mm x 150mm of suitable strength around frame

Note: For connection to UltraRib, see pages 12-13; for TwinWall see page 11

Manholes, Gullies, French Drains SUDS and Highway Drainage

Products to simplify access provision in all areas of underground drainage.

Manhole Bases

OSMA 750mm Manhole Bases are designed for use at depths of up to 10 metres. They eliminate the need for complex manual benching within traditionally constructed manholes.

- Choice of equal or unequal bases for OsmoDrain
 - 6D875: 4x110mm, 1x160mm inlets
 - 6D876: 5x160mm inlets
- Simplifies construction of traditional manholes
- Choice of equal or unequal bases for UltraRib
 - 6UR875: 4x110mm, 1x150mm
 - 6UR876: 5x150mm
 - 9UR878: 4x150mm, 1x225mm
 - 9UR877: 3x225mm

Note: TwinWall uses the above via adaptors

Key installation points

- Inlets and outlets are sealed. Remove the spigot end of any required inlet or outlet with a fine tooth saw
- Connect Manhole Base using either Pipe Coupler or Double Socketed Bend
 - For OsmoDrain – Follow the standard ring seal jointing method
 - If using Manhole Base 6D876 and a 110mm connection is required: fit a Reducer 6D099 into the socket of either the Coupler or Bend

Note: For connection to UltraRib, see pages 12-13; for TwinWall see page 11

Fig. 18 Manhole Base – typical installation

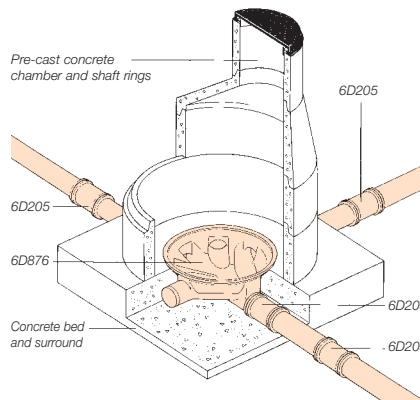

Fig. 19 Bottle Gully installation with horizontal inlet

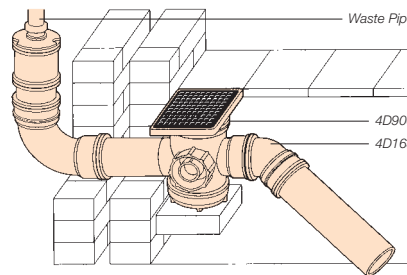
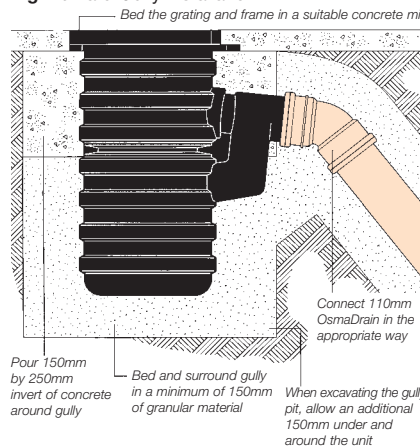

Fig. 20 Yard Gully installation



Bottle Gully

OSMA Bottle Gullies offer a neat, practical and compact alternative to traditional gullies, and provide distinct installation and maintenance advantages:

- Direct roddable access to the drainage system
 - Drainage can be taken straight to an oblique junction, rather than an inspection chamber (as is necessary when a hopper plus “P” trap is used)
- The body of the gullies can rotate by means of a push-fit joint. This:
 - ensures that the unit can be aligned perfectly with paving slabs
 - assists the installer with unpredictable conditions on site
- Bottle Gully Riser 4D916 enables the Gully to be installed at invert depths of up to 600mm

The OSMA Bottle Gully can accommodate horizontal or vertical connections and has the option of:

- Sealed Access Cover 4D915 for internal applications
- Ductile Iron Grating 4D919 for areas where light vehicles have access. Surround Gully with concrete 150mm deep

Yard Gully

The single unit OSMA Yard Gully incorporates an integral trap and removable rubber plug for easy rodding. This robust unit does not require a complete concrete surround, see Fig. 20, as is the case with most competitor gullies. For BS EN 124-B125 Medium Duty Loading requirements use a Ductile Iron Grating and Frame 4D810.

Also available:

OSMA Universal Gully comprising Universal Gully Trap and any one of five different Hoppers

French drain

French drains, constructed using perforated OsmoDrain pipe or OSMA Land Drainage, are ideal for:

- Drainage of concreted areas such as roads, car parks, airfields
- Preventing build up of water pressure behind a retaining wall
- Drainage to relieve water pressure at the bottom of banks, where contractor has cut into existing ground

In very fine, silty soils, wrap a geotextile membrane around the drainage pipe to prevent blockage (Type 8 – Fin Drain).

Fig. 21 Draining paved area via french drain

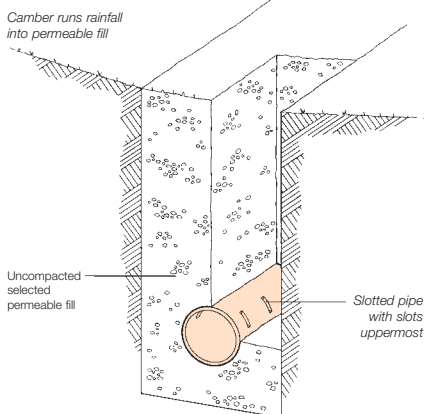
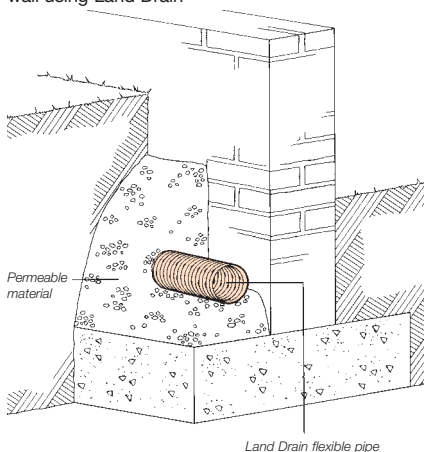

Fig. 22 French drain behind a retaining wall using Land Drain



OSMA TwinWall

Cost effective twin wall pipe system suitable for all surface and storm water drainage requirements where Local Authority adoption is not required. The twin wall construction helps to maintain flexibility and reduce the possibility of impact damage on site.

Comprehensive range

- Sizes: 100mm, 150mm, 225mm, 300mm, 375mm, 450mm, 500mm, 600mm
- 100m – 300m made from recycled HDPE, 300m – 600m made from Polypropylene
- Supplied in 6m lengths, perforated, half perforated and unperforated
- Long lengths reduce the need for joints and assist both flow capacity and self-cleansing velocity
- Uniquely includes adaptors for connection to:
 - Inspection Chambers, including Non-entry Inspection Chamber (NIC) to max. 3m invert
 - Manhole Bases

Versatile system

- Lightweight, flexible and easy to install
- BBA certified for use in highway drainage and non-adoptable construction projects, BBA certificate 02/3940 and 02/H070
- Perforated TwinWall exceeds the Department of Transport's minimum requirement of 1000mm² per metre length
- May be used as an alternative to systems listed in Table 5/1 of the Manual of Contract Documents for Highway Works (MCHW) Vol.5

Suitable for all applications

OSMA TwinWall is suitable for all non-adoptable surface and sub-surface water drainage requirements, including:

- Highway filter and carrier drains
- Rail track drainage
- Golf course and other land drainage
- Surface water drains, for example on industrial or commercial developments
- Leachate drainage

Fig. 23 Connection to BS 1401 pipe

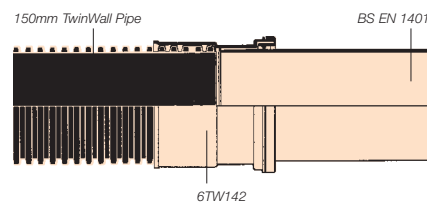

Manholes, Gullies, French Drains, SUDS and Highway Drainage

Easy, versatile connection

- Pipe-to-pipe or pipe-to-fitting connections made using fast, simple ring seal joints
- Connection to UltraRib Manhole Base: use D/S Adaptors 6TW148 or 9TW148
- Connection to NIC: use Base 6UR936/937. Connect to pipe via S/S Adaptor 6TW145

Fig. 24 150mm UR Socket to TwinWall Spigot

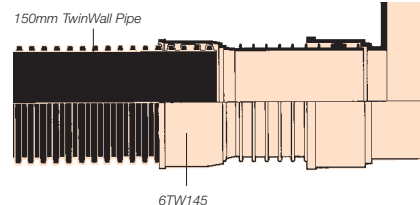

Sewers for Adoption

OSMA UltraRib

A 150mm, 225mm, and 300mm structured wall drainage system for use in both foul and surface water applications:

- ▲ Included in Sewers for Adoption 5th Edition, Civil Engineering Specification for the Water Industry and Specification for Highway Works
- ▲ External ribs provide exceptional axial rigidity and radial strength
- ▲ Smooth inner surface for enhanced flow

Comprehensive range

This fully socketed system of pipe and fittings includes:

- ▲ Adaptors to virtually any other type of pipe, including clay, concrete and plastic
- ▲ 750mm diameter Manhole Bases for easy and cost-effective access provision
- ▲ Universal Inspection Chambers (UIC), 450mm diameter system suitable for depths up to 1.2m
- ▲ Non-entry Inspection Chamber (NIC), meeting revised Part H 2002 for non-man entry down to 3m invert depth *see also page 9*
- ▲ Road Gully

Ideal for sewer applications

OSMA UltraRib structured wall drainage offers many cost, installation and performance benefits over rigid (clay and concrete) sewer systems, including:

- ▲ The health and safety benefits of lighter materials and easier handling
- ▲ Practical benefits such as fewer joints and faster installation
- ▲ Benefits in performance such as less likelihood of blockages due to the smooth, non-porous bore

Simple, fast installation...

High performance, watertight joints are easily made by placing a sealing ring between the second and third external reinforcing ribs of a pipe spigot. This is then inserted into a socket:

- ▲ No chamfering of pipe ends
- ▲ No possibility of joint displacement during installation

...even in poor ground conditions

UltraRib is reinforced externally with a pattern of integral, concentric ribs which provide exceptional axial rigidity and enhanced radial strength. This enables UltraRib to be used in poor or heavy ground conditions, even when laying pipework to shallow gradients.

Third Party Approval

The OSMA UltraRib system has a proven history and to support this high level of quality a number of third party approvals have been achieved covering both foul and surface water applications.

These include:

- ▲ BSI Kitemark to the Water Industry Specification WIS 4-35-01
- ▲ British Board of Agrément (BBA) certificate numbers 98/3472 and 89/R 046

Key Installation Details

Best Practice procedures for installation of sewers for adoption have been established, in consultation with the Water Industry, by the Plastic Pipes Group of the British Plastics Federation. These are summarised and illustrated below.

Trench (Figs. 26, 27 & 28)

- Allow minimum 100mm below base of pipe (150mm if concrete bed)
- Width: pipe diameter plus min. 300mm

Bedding

- Must fully support pipeline base: no voids (Figs. 26, 27 & 28)
- Materials: (as-dug/imported) to WIS 4.08.02; (concrete) C20 grade

Cutting

- With hand-saw, midway between corrugations
- Cut square – remove swarf

Fitting seal

- For UltraRib, between 2nd and 3rd ribs

Fig. 26 Granular Bed and Surround

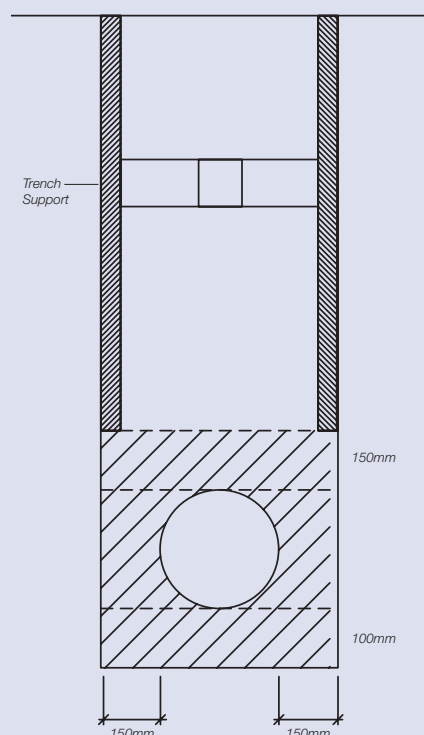

Joining

- Lubricate inner surface of socket and ring seal
- Check alignment
- Place pipe end in socket and lever fully home

Sidefill (Figs. 26, 27 & 28)

- Materials: as Bedding
- Fill both sides simultaneously (to avoid pipe displacement) – and compact

Backfill

- Materials: as Bedding
- Initial: 150mm above pipe crown – hand tamp (Figs. 26, 27 & 28)
- Subsequent: no mechanical compaction until 300mm above crown
- Continue backfill with 'as-dug' material

Testing

- Air testing as specified in Sewers for Adoption
- CCTV check for alignment, obstructions, defects

Fig. 27 Concrete Protection Slab

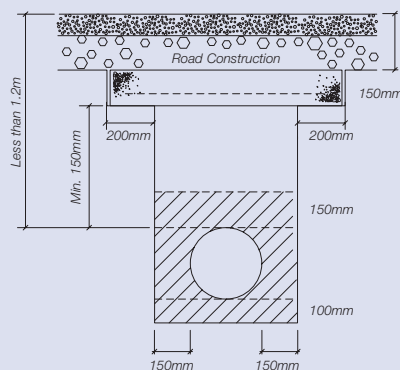

Pipe Protection

- If pipe is less than 1.2m under roadways: add 150mm concrete slab (Fig. 27):
 - Minimum 150mm above pipe crown
 - Minimum 200mm beyond trench side
- Concrete bed/surround if <1.2m pipe depth or under roadway
 - Minimum 150mm below pipe base
 - Include flexible joints at mouth of pipe sockets (Fig. 28)

Fig. 28 Flexible Joint in Concrete Bed and Surround

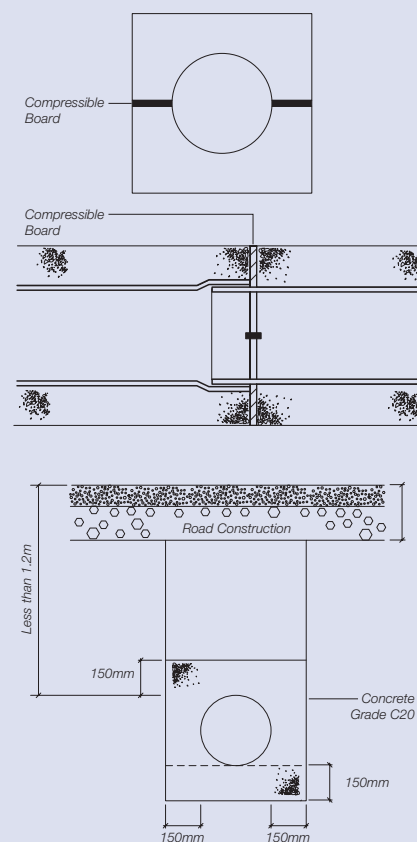

Sewers for Adoption

Channel Drainage

The OSMA PolyChannel range of polymer concrete channel drainage products offer a complete and integrated surface water drainage system for all applications.

Available in widths of 100mm, 150mm, 200mm and 300mm, the PolyChannel system includes:

- Range of flats and slopes for all project requirements
- Shallow 'Piccolo' channels for restricted depth construction areas
- SK Channel and grating available in stainless steel for food hygiene applications
- Wide choice of gratings
- Full range of accessories

SK Channel

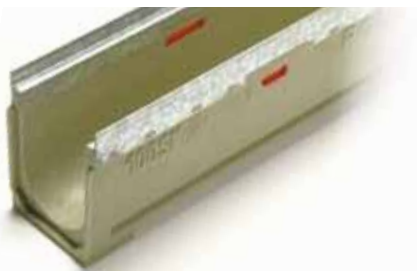

Note: Gratings to suit application

SKS Channel



Enhanced performance

Manufactured in PolyDyn® polyester concrete, OSMA PolyChannels offer enhanced long term performance as well as being easier to handle, machine, cut and drill on site.

- Easy handling and storage
 - Due to the lightweight, modular nature of the channels
 - Self cleaning
 - Due to mirror smooth internal finish and pre-formed gradients of the sloped channels
 - Easy to install
 - Each channel has a male and female end, simplifying alignment and sealing
 - Special components for corners and T-junctions
 - Frost anchors
 - Anchoring ribs that run the full length of the channel, eliminating the risk of lifting
 - Versatility
 - Smooth, straight outside walls for easy installation within concrete, asphalt or block paving finishes
- ### Fit for purpose
- OSMA PolyChannel Standards and Approvals
- European Standard EN 1433
 - SK range (NW 150, 200 and 300) with enhanced steel edges meets requirement of European Standard EN 1433
 - DIN 19580 compliance
 - The loading classifications of SK and SKS gratings

Key design considerations

- Area to be drained
 - Multiply the total length of the catchment area by its width to calculate the total area to be drained (See below).

Fig. 29 Area to be drained

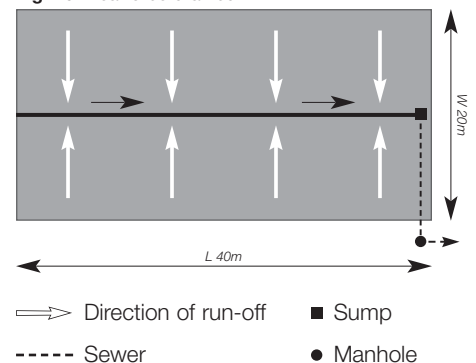

- Rainfall intensity/depth of channel
 - Ensure correct depth of channel is used in order to have sufficient capacity to cope in a downpour. In most cases, the following rainfall intensity rates are applicable:
 - 50mm/hr for paved areas on which ponding can be tolerated during heavy storms and for a few minutes afterwards
 - 75 mm/hr for sloping surfaces where ponding cannot occur and for flat surfaces where ponding cannot normally be tolerated
- Ground slope
- Type and position of outlet
- Loading requirement (see *Typical Application Loadings*)
- Site aesthetics – grating material/colour

Table 2: Typical Application Loadings

Application	Channel Systems	Loading Class	Recommended Grating	Part No.
Domestic/Housing	OsmaChannel OSMA Threshold OSMA RainChannel	A15 A15 A15	Grating supplied c/w channel	-
Cycle Paths	SK	B125/C250	Galvanised slotted	100SK442/100SK508
Car Parks – Restricted/ Small Domestic	SK	B125/C250	Galvanised slotted	100SK442/100SK508
Industrial/Factories, etc – non-loading	SK	B125/C250	Galvanised slotted	100SK442/100SK508
Sports Stadium – Concourses	SK	B125/C250	Galvanised slotted	100SK442/100SK508
Pedestrian Areas/ Shopping precincts	SK	C250	Cast slotted heel/PolySpectra	100SK508
Sports Stadium – Car Parks	SK	C250	Cast slotted heel or standard/ Galvanised slotted	100SK508/100SK426
Car Parks – Commercial/ Industrial/Retail	SK	C250	Cast slotted heel or standard	100SK508
Shower Areas	SKCR	C250	PolySpectra	100SK581
Petrol Stations/Forecourts (non-turning)	SK	C250/E600	Cast slotted heel or standard/ Ductile slotted	100SK508/100SK504
Industrial – Food/Chemical	SKCR	C250/E600	PolySpectra/Stainless steel slotted	100SK581/100SK427
Industrial/Factories, etc – loading (non-turning)	SK	E600	Ductile slotted	100SK504
Warehouse/Dock Areas – loading (non-turning)	SK	E600	Ductile slotted	100SK504
Warehouse/Dock Areas – loading (turning)	SKS	F900	Grating supplied c/w channel	-
Petrol Stations/Forecourts (turning)	SKS/SKSH	F900	Grating supplied c/w channel	-
Industrial/Factories, etc – loading (turning)	SKS	F900	Grating supplied c/w channel	-
Airports	SKS/SKSH	F900	Grating supplied c/w channel	-

PolyCalc design support

The Wavin Technical Design team offer a channel drainage design service using PolyCalc, a bespoke hydraulic calculation programme specifically created to take into account the inherent attributes of PolyChannel systems.

For FREE channel drainage design support, please contact the Wavin Technical Design on:

01249 766655

Channel Drainage

Channel Drainage continued

Table 3: Minimum Concrete Bed and Surrounds

Class	Load	Minimum Concrete Bed	Minimum Concrete Surround	Minimum Concrete Strength
A	15N/mm ²	100mm	100mm	15N/mm ²
B	125N/mm ²	100mm	100mm	20N/mm ²
C	250N/mm ²	150mm	150mm	25N/mm ²
D	400N/mm ²	200mm	200mm	25N/mm ²
E	600N/mm ²	200mm	200mm	25N/mm ²
F	900N/mm ²	200mm	200mm	25N/mm ²

Note: The above table is provided as a guide only, as each installation should be designed individually taking into account the load bearing capacity (CBR) of the sub grades and types of application.

Minimum criteria for Class loadings

The OSMA PolyChannel range should be installed with due recognition of the anticipated loading for the specific application. Heavier-duty applications require extra bedding and surround thicknesses.

Applications of PolyChannel SK range finished with block paving can cover Classes A-C (15-250N/mm²). For the relevant minimum dimensions of bed and surround, and minimum concrete strength, see Table 3.

PolyChannel SKS range applications finished with asphalt cover all Classes A-F (15-900N/mm²), including locations subject to intense levels of heavy traffic. For the relevant minimum dimensions of bed and surround, and minimum concrete strength, see Table 3.

Fig. 30 SK finished in block paving

Blocks to be laid on 30-50cm wide concrete bed of same strength as bedding concrete and jointed perpendicularly to the channel

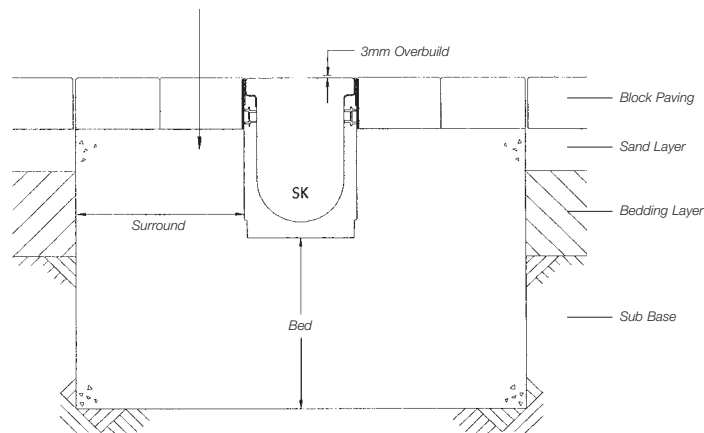
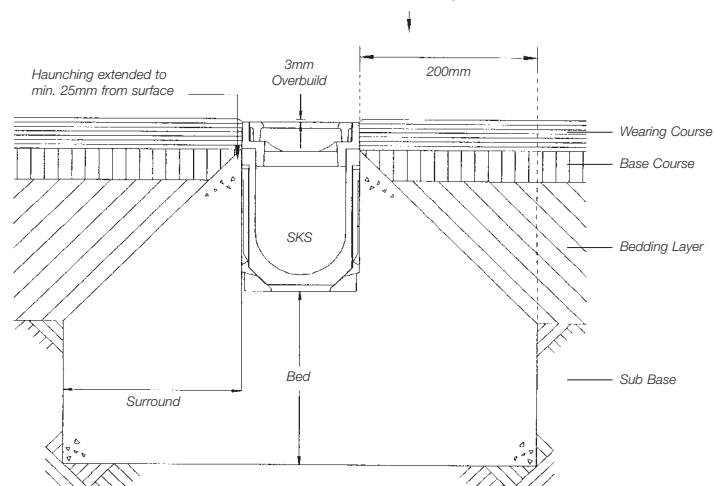

Fig. 31 SKS finished in asphalt

For extremely heavy applications (E600/F900) extend surround to surface, 200mm either side of channel



Key installation points

- ▲ Always start from outlet point when setting out and installing channels
- ▲ Ensure that arrows on the side of channels point in the direction of flow
- ▲ Knock out connectors as required, using a drill and sharp chisel
- ▲ Pour concrete bedding and, beginning at the outlet position, lower channels into position using the male/female interlock
- ▲ Check alignments and install grating before pouring concrete surround
- ▲ Concrete surround should finish 3mm ABOVE channel and grating top surface
 - If installing within concrete slab, locate longitudinal and transverse expansion joints prior to concreting
 - For blocked paved areas, set the first row of blocks into the concrete surround
 - Do not lay tarmac right up to the channel
- ▲ After installation lift grating to remove any debris and flush the system through

Corners (L Junctions) and T Junctions

The NW100 SK and SKS ranges include an 0.5m length Flat Junction Channel, with purpose designed side knockouts to connect channels. This avoids the need for cutting channels when installing corners or T junctions.

Fig. 32 Typical junction details

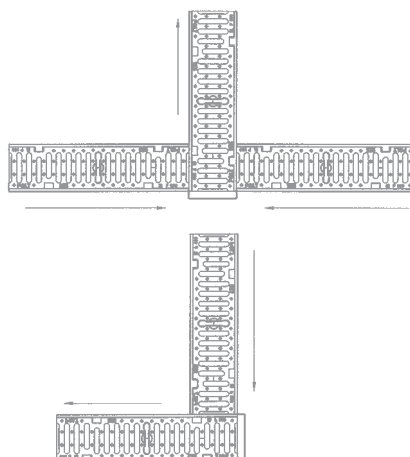

Mitre joints

Make vertical cut through both channels at the same time. Then butt together on the concrete bed and surround with concrete. Any discrepancies in the cut can be made good using either concrete or an appropriate sealant.

Note: Only recommended for OsmaChannel and SK systems with a load class of up to B125

Fig. 33 90° mitred channel and grating joint detail

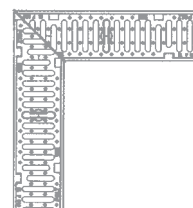

Channel Drainage
continued

Stormwater Management

For residential, commercial and industrial attenuation and soakaway/infiltration applications

Sustainable development and Sustainable Drainage Systems (SUDS) are increasingly important considerations in building and construction today. This can be seen in:

- Environment Agency initiatives
- Policy statements such as PPG25
- The revised Building Regulations Part H3: Section 0.2 which encourages 'alternative methods of drainage other than connection to a public surface water sewer wherever technically feasible'.

OSMA Water Management systems provide the most cost-effective and versatile means to achieve all the principal aims of SUDS.

- Limiting run off by controlling and reducing the volume discharge into existing main sewers and watercourse
- Improving amenity by significantly reducing the risk of flooding and its consequences

The AquaCell® Systems:

The AquaCell systems are a fully tried and tested modular technique for managing excessive rainfall by creating an underground structure as either a temporary storage tank or a soakaway:

- **AquaCell** (blue unit) for trafficked locations
- **AquaCell Lite** (green unit) for landscaped and non-trafficked sites

Fig. 34 Positioning the top layer geomembrane (or geotextile) wrap



AquaCell Lite



AquaCell

AquaCell systems: features and benefits

Applicable to BOTH systems

- Suitable for both soakaway and storage tanks
- Modular: lightweight and versatile
- 95% void ratio: holds 190 litres of water per unit
- Safer option than open or above ground storage structures
- Easy to install and handle
- Allows 'brick-bonding' assembly for extra stability: no extra adaptors needed
- Proven clip and peg system to secure units
- Full range of ancillaries: including silt trap and adaptors.

Fig. 35 Small housing soakaway



Fig. 36 Highway drainage soakaway

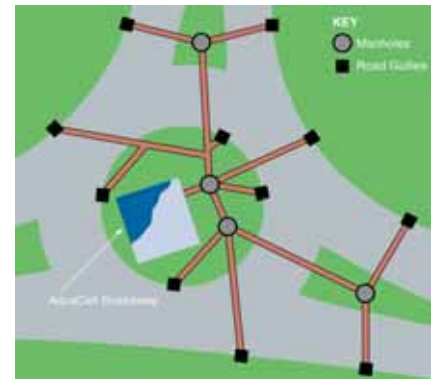

Overview of AquaCell® Systems

Both OSMA AquaCell and AquaCell Lite units are modular in shape (1.0m x 0.5m x 0.4m), have a 95% void and a capacity of 190 litres per unit. The lightweight, polypropylene units are easy to handle and install. Original AquaCell (blue unit) weigh 9kg each and AquaCell Lite (green unit) weigh 7kg each. Individual units are securely linked together using special clips and shear connectors and can be

assembled quickly on site into whatever configuration suits each specific location. AquaCell geocellular systems also allow 'brick-bonding', which can give extra stability, without the need for additional connector pieces.

Wrapped for infiltration or storage

The complete assembly is wrapped in either geotextile or a geomembrane (wrapped with a protective fleece). For pervious soils, the geotextile allows

infiltration of stormwater into the surrounding ground. Where the ground is impervious (e.g. clay) or where infiltration is not desirable, the geomembrane encapsulated assembly holds stormwater in temporary storage until local drainage flows can accept it for normal disposal.

Fig. 37 AquaCell typical on-line water storage detail

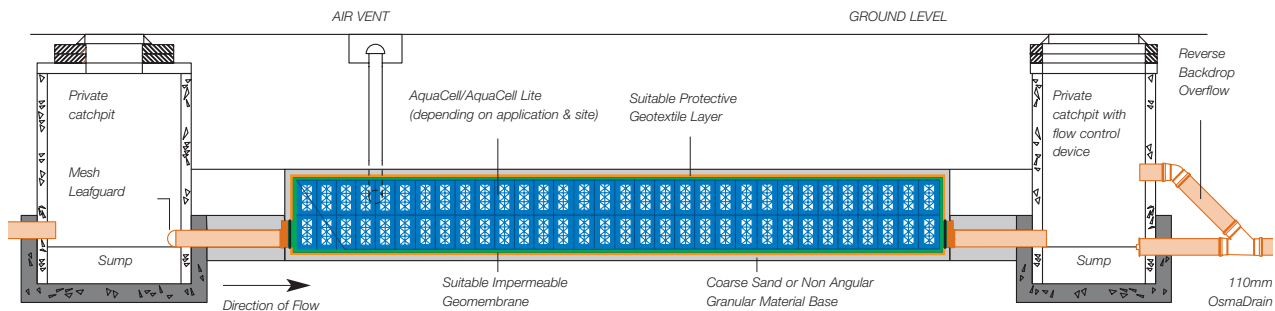
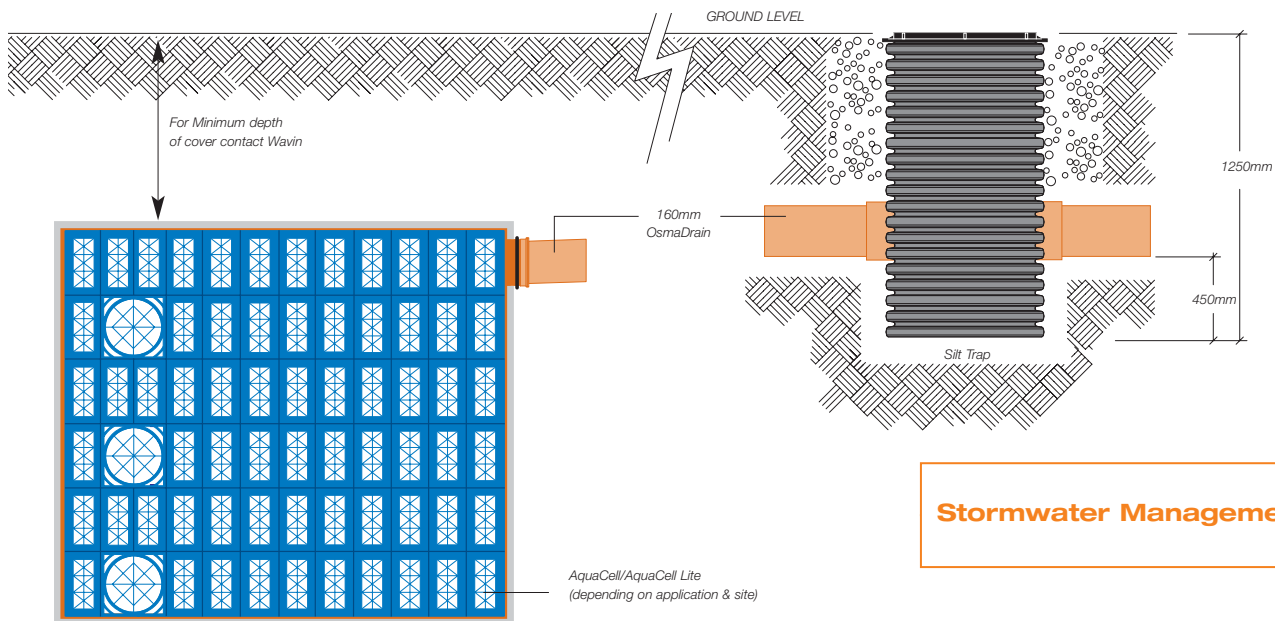

Fig. 38 AquaCell typical soakaway application



Stormwater Management

Stormwater Management continued

AquaCell for trafficked sites

OSMA AquaCell is ideal for areas subject to regular and heavy traffic loading, and particularly for larger projects.

AquaCell



In addition to features and benefits applicable to BOTH systems those specifically applicable to traffickable AquaCell (blue unit) include:

Typical applications:



Industrial/commercial areas

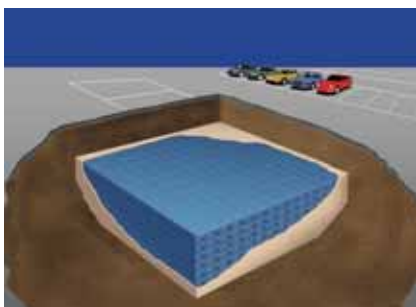

Car parks

- ▲ BBA approved and can meet technical requirements of NHBC
- ▲ Proven vertical loading capacity: **56 tonnes/m²**
- ▲ Proven lateral loading capacity: **7.75 tonnes/m²**
- ▲ For installations both up to and exceeding 1.5 metres deep
- ▲ Distinctive BLUE colour – easy to identify
- ▲ Designed for all configurations and applications, including both shallow and deeper installations:
 - Ideal for all sizes of project including major attenuation schemes

AquaCell Lite for landscaped

OSMA AquaCell Lite has been designed and developed for landscaped and other traffic-free areas where heavy loading capability is not required.

AquaCell Lite



In addition to features and benefits applicable to BOTH systems those specifically applicable to AquaCell Lite (green unit) include:

- ▲ Proven vertical loading capacity: **17.5 tonnes/m²**
- ▲ Proven lateral loading capacity: **4.0 tonnes/m²**

- ▲ For installation depth (to base of units) of up to 1.5 metres maximum
- ▲ Built-in 'hand holes' for easy carrying/handling
- ▲ Distinctive GREEN colour – easy to identify
- ▲ Specifically designed for restricted depth, low-loaded, landscaped sites:
 - Ideal for smaller projects

Note: NOT suitable for locations subject to high watertable

Typical applications:



Domestic gardens



Grassed and leisure areas

For further information regarding the Stormwater Management Systems, please refer to the Product and Installation Guide (ref. WM420).

Fig. 39 Garastor: Typical system (garage void)

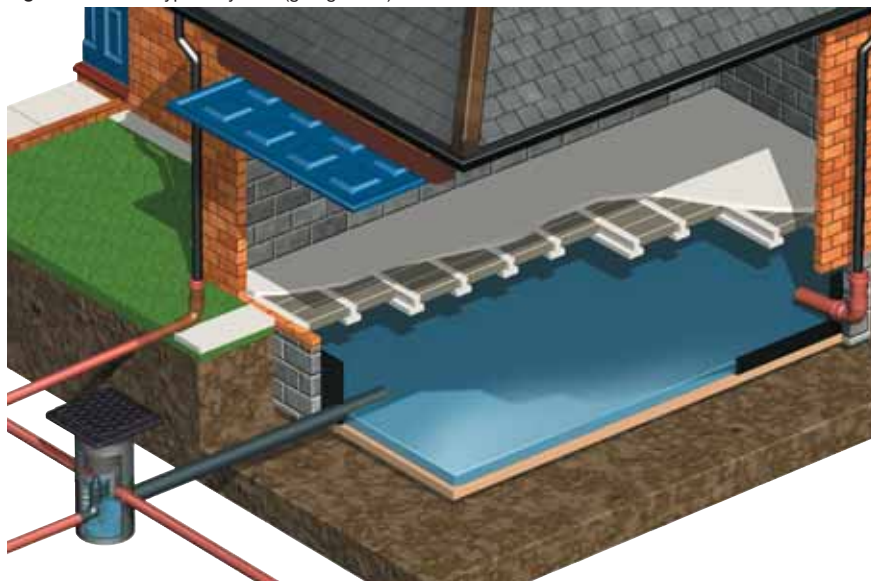

Fig. 40 Garastor: Typical system (garden void)

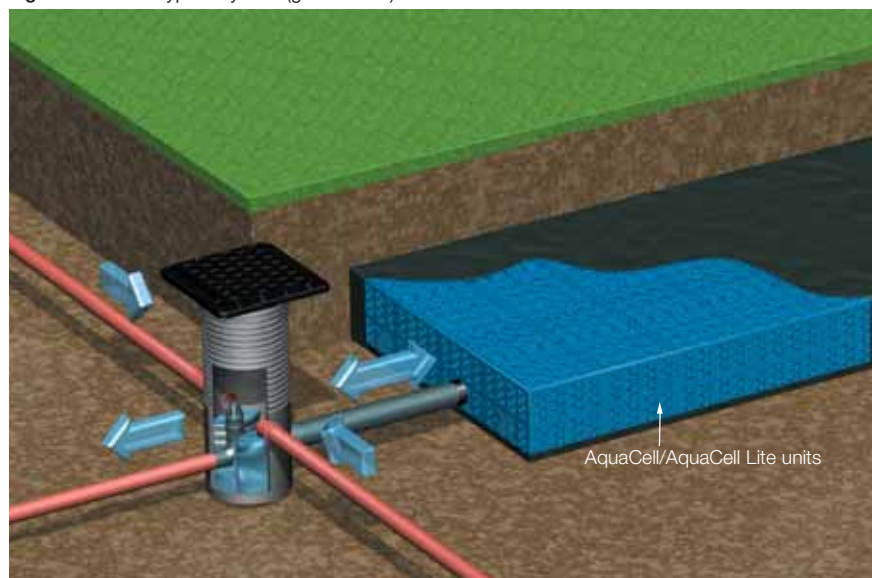
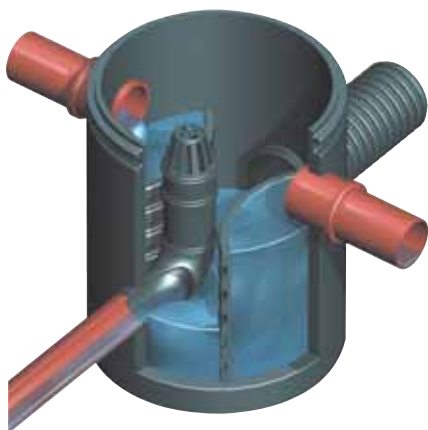

Fig. 41 Internal view of Garastor



Garastor®

A polypropylene flow control chamber connected to a water storage reservoir either made up of AquaCell units or located in a void beneath the garage of individual houses.

- Low maintenance free, with no moving parts or filters
- Efficient and cost effective
- Run-off reverts to that of a greenfield site
- Safer than open/above ground storage structures
- Meets Building Regulations Part H3, 2002 recommendations
- Garastor is manufactured under licence (Patent Number GB2357093)
- Two versions are available, both 500mm in diameter:
 - 6SC500 – normally 1m deep for garage installations (with 300mm storage depth capacity)
 - 6SC501 – 1.25m deep for use with AquaCell (with 400mm storage depth capacity)
- When Garastor is used in conjunction with AquaCell, the configuration of units must be no deeper than 1 AquaCell unit
- If site conditions require a deeper Garastor unit, use the 500mm Extension Kit (6SC205 – consisting of a coupler and two ring seals) with a shaft of 500mm TwinWall, cut to suit, to extend the Garastor unit

Stormwater Management
continued

Rainwater and Soil & Waste Drainage



Rainwater Systems

Complete solution for rainwater drainage

OSMA offers a complete solution for all rainwater drainage requirements for today's buildings. These precision-manufactured plastic systems meet or exceed all relevant British and European standards and offer reliable, long lasting performance with minimum maintenance.

- Integrated drainage solutions from a single source
- Ensuring full system compatibility
- Easy design, specification and ordering
- Simple and fast to install

Maximum Effective Roof Area (m²)

System	Outlet at end of gutter run 		Outlet at centre of gutter run 	
	level	Gutter laid at fall 1:600	level	Gutter laid at fall 1:600
RoundLine	46	57	92	115
SuperLine	75	90	151	180
RoofLine	111	155	222	310
Mini-Fit	14	20	28	40
DeepLine	90	110	180	220
SquareLine	53	75	106	148
StormLine	96	110	192	220

Note: The roof areas capable of being drained are calculated in accordance with BS EN 12056:3:2000, to which reference should be made before varying design considerations

Roof area calculation

There are two methods of calculating Effective Roof Area, which allows for the effects of wind.

Procedure A

BS EN 12056:Part3: 2000

- 1 Measure in metres:
 - A Plan length from eaves to ridge
 - B Height of roof from eaves to ridge
 - C Length of roof
- 2 Use the formula specified in BS EN 12056:3:2000

$$\text{Effective Roof Area (in m}^2\text{)} = (A + \frac{B}{2}) \times C$$
- 3 Check this figure against the capacity of OSMA systems set out in Table above.

Procedure B

Building Regulations Part H 1990

- 1 Measure roof plan area in square metres:
 Length (L) x Width (W) = Area (m²)
- 2 To find Effective Roof Area, multiply roof plan area as follows, according to angle of pitch:
 - if 30° pitch – Area x 1.29
 - if 45° pitch – Area x 1.5
 - if 60° pitch – Area x 1.87

Fig. 44 Pitched roof

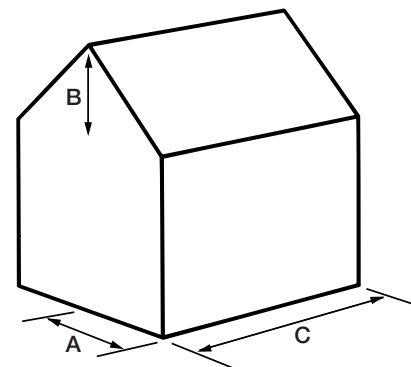

FREE calculation service

Wavin Technical Department offers a FREE roof area calculation service, with recommended drainage solutions. For assistance please call Wavin Technical Design on:

01249 766655

RoundLine

Classic 112mm [4½"] half-round gutter system to BS 4576: Part 1: 1989



SuperLine

Large domestic 125mm [5"] half-round gutter system to BS 4576: Part 1: 1989



RoofLine

Industrial very high capacity 150mm [6"] half-round gutter system to BS 4576: Part 1: 1989



DeepLine

High capacity 113mm [4½"] semi-elliptical gutter system



SquareLine

Classic 100mm [4"] square section gutter system



StormLine

High capacity 111x97mm [4¼x3¾"] Ogee gutter system



Also available:

Mini-Fit

75mm [3"] half-round gutter system for porches, conservatories, and other small roof areas



Key:

- Black
- Grey
- White
- Brown

Soil and Waste Systems

For all types of building

The OSMA range offers an extensive choice of systems to meet performance installation requirements for all types of building, from single dwelling to large apartment block.

Systems are equally suitable for low rise and high rise applications, and include a full range of components including BS EN 12380 A1 Rating certified Air Admittance Valve, access fittings, bends, branches and connectors for all WC configurations.

- ▲ Push-fit PVC-U soil system for simple and efficient installation
- ▲ Solvent weld PVC-U soil system with secure method of jointing
- ▲ Choice of two push-fit and two solvent weld waste systems
- ▲ Comprehensive range of waste fittings, including tubular and bottle traps and shower gullies
- ▲ Push-fit and solvent weld overflow systems

Technical assistance

Wavin offers comprehensive design and installation support, with advice on the most cost-effective solutions for specific projects in order to:

- ▲ reduce drain connections
- ▲ reduce costs
- ▲ meet best practice

Fig. 45 Typical bathroom layout/Connections to waste

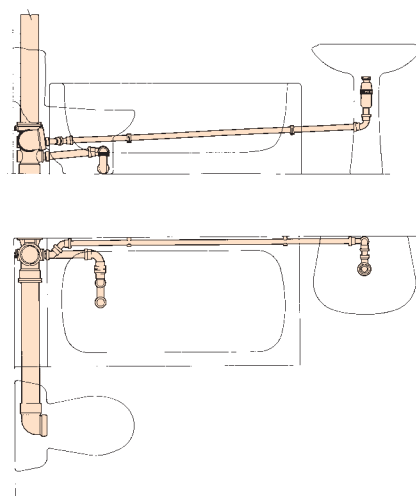

Stub stacks

Ideal for simple and cost effective connection of downstairs WCs direct to drainage.

Fig. 46 Typical stub stack arrangement

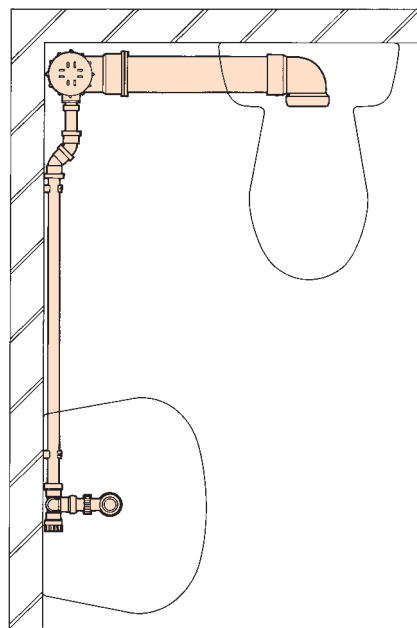
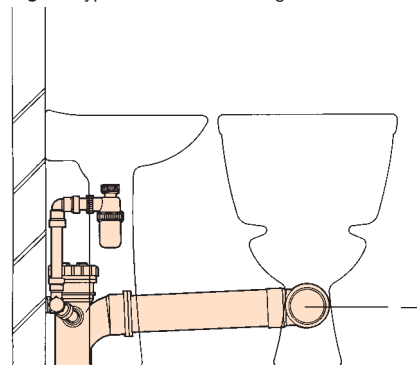

Rainwater and Soil & Waste Drainage